

Please check the examination details below before entering your candidate information

Candidate surname					Other names				
Centre Number					Candidate Number				
<input type="text"/>	<input type="text"/>	<input type="text"/>	<input type="text"/>	<input type="text"/>	<input type="text"/>	<input type="text"/>	<input type="text"/>	<input type="text"/>	<input type="text"/>

**Pearson Edexcel International Advanced Level**

**Monday 20 January 2025**

Afternoon (Time: 1 hour 20 minutes) **Paper reference** **WPH16/01**

**Physics** □ □

**International Advanced Level**

**UNIT 6: Practical Skills in Physics II**

<b>You must have:</b> Scientific calculator, ruler	<b>Total Marks</b>
---	--------------------

### Instructions

- Use **black** ink or ball-point pen.
- If pencil is used for diagrams/sketches/graphs it must be dark (HB or B).
- **Fill in the boxes** at the top of this page with your name, centre number and candidate number.
- Answer **all** questions.
- Answer the questions in the spaces provided  
– *there may be more space than you need.*
- **Show all your working out** in calculations and **include units** where appropriate.

### Information

- The total mark for this paper is 50.
- The marks for **each** question are shown in brackets  
– *use this as a guide as to how much time to spend on each question.*
- The list of data, formulae and relationships is printed at the end of this booklet.

### Advice

- Read each question carefully before you start to answer it.
- Try to answer every question.
- Check your answers if you have time at the end.

Turn over ►

P78480A

©2025 Pearson Education Ltd.  
H:1/1/1/



  
Pearson

**Answer ALL questions.**

- 1 A student investigated the pressure of a fixed volume of air using the apparatus shown.

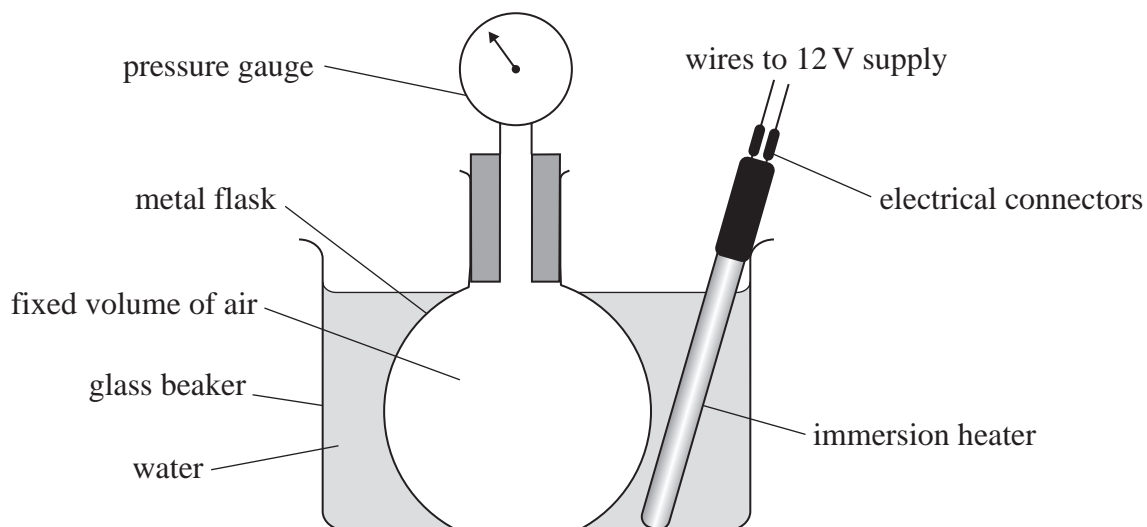

- (a) The student used the immersion heater to heat the water in the beaker.

Identify **one** health and safety issue and how it should be dealt with.

(2)

.....

.....

.....

.....

- (b) The student determined the temperature  $\theta$  of the fixed volume of air.

Describe an accurate method to determine a single value of  $\theta$ .

(3)

.....

.....

.....

.....

.....

.....

.....



- (c) The student recorded  $\theta$  at a pressure of 110 kPa. He repeated the measurement several times as the flask was cooled and reheated.

He recorded the following measurements.

$\theta / ^\circ\text{C}$	42.5	41.0	42.0	43.5
---------------------------	------	------	------	------

- (i) Determine the mean value of  $\theta$ .

(1)

Mean  $\theta =$  .....

- (ii) Determine the percentage uncertainty in the mean value of  $\theta$ .

(2)

Percentage uncertainty = .....

- (iii) The diameter of the flask was 15 cm.

Determine the number of air molecules in the flask.

You may assume the volume of air is spherical.

(4)

Number of air molecules = .....

**(Total for Question 1 = 12 marks)**

DO NOT WRITE IN THIS AREA

DO NOT WRITE IN THIS AREA

DO NOT WRITE IN THIS AREA



2 A student investigated how varying the power input  $P$  to a 12 V filament bulb affected the brightness of the filament bulb.

(a) Complete the circuit diagram for the circuit the student could use in this investigation.

(2)

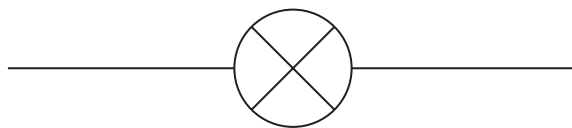

DO NOT WRITE IN THIS AREA

DO NOT WRITE IN THIS AREA

DO NOT WRITE IN THIS AREA





DO NOT WRITE IN THIS AREA

DO NOT WRITE IN THIS AREA

DO NOT WRITE IN THIS AREA

**BLANK PAGE**



- 3 A student investigated the damped oscillations of a pendulum using the apparatus shown.

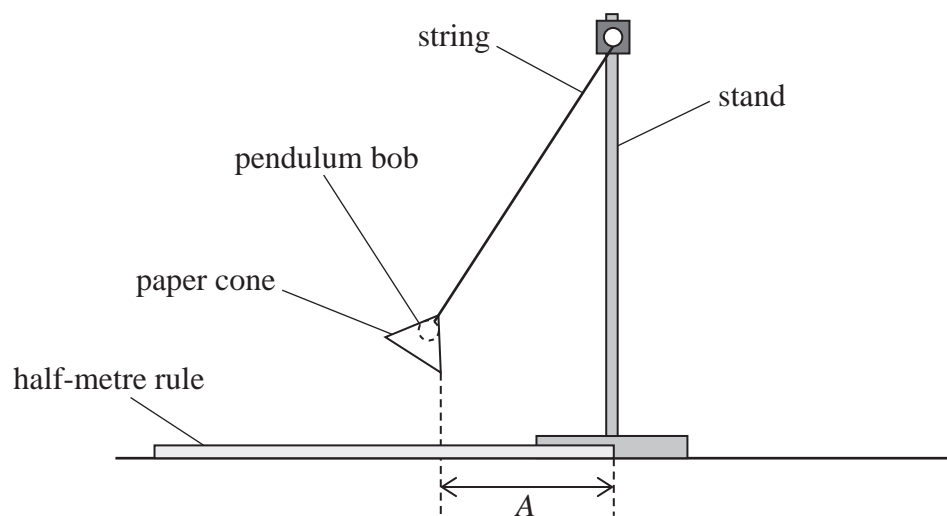

The paper cone acted as a damper.

The student displaced the cone and allowed the pendulum to oscillate.

He measured the amplitude  $A$  every 5 oscillations and recorded the value to the nearest 5 mm.

- (a) Give **two** reasons why it would **not** be appropriate to record  $A$  to the nearest mm.

(2)

.....

.....

.....

.....



(b) The relationship between  $A$  and the number of oscillations  $n$  is

$$A = A_0 e^{-\lambda n}$$

where  $A_0$  is the initial amplitude and  $\lambda$  is a constant.

(i) Explain how a graph of  $\ln A$  against  $n$  can be used to determine the value of  $\lambda$ .

(2)

(ii) The student recorded the following results.

$n$	$A / \text{cm}$	
5	8.5	
10	7.0	
15	5.5	
20	5.0	
25	4.0	
30	3.5	

Plot a graph of  $\ln A$  against  $n$  on the grid opposite.

Use the additional column for your processed data.

(5)

(iii) Determine the value of  $\lambda$  from the graph.

(3)

$\lambda = \dots\dots\dots$



DO NOT WRITE IN THIS AREA

DO NOT WRITE IN THIS AREA

DO NOT WRITE IN THIS AREA

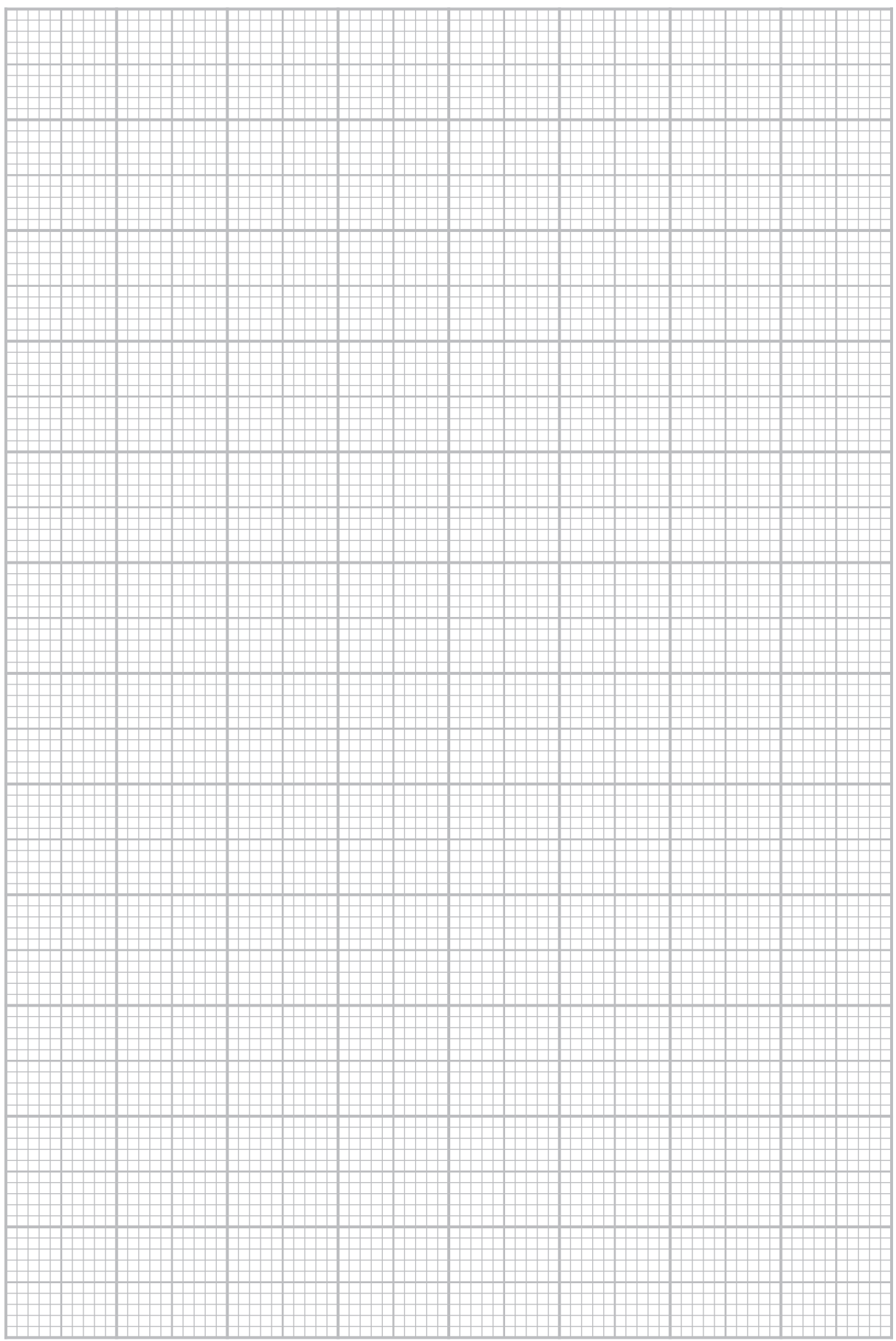

(iv) Determine the value of  $A_0$  from the graph.

(3)

$A_0 = \dots\dots\dots$

(v) Explain why the value of  $A_0$  determined from the graph may not be the true value of  $A_0$ .

(2)

**(Total for Question 3 = 17 marks)**

DO NOT WRITE IN THIS AREA

DO NOT WRITE IN THIS AREA

DO NOT WRITE IN THIS AREA



4 A student set up a ramp, as shown.

The student placed two markers, a distance  $s$  apart, on the ramp.

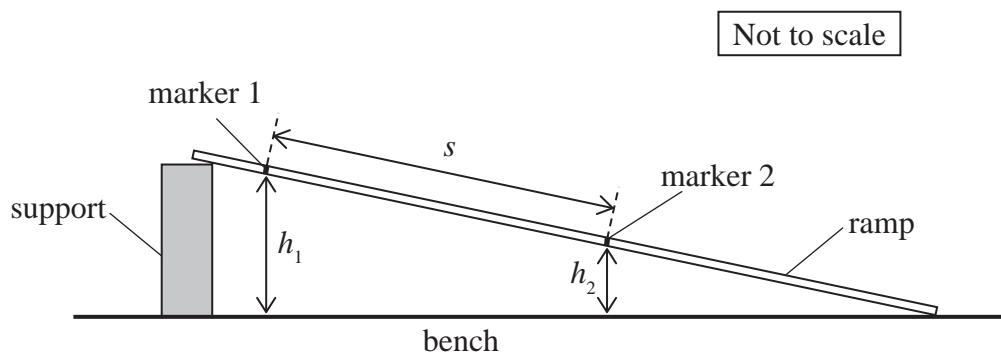

(a) The student used a metre rule to measure the heights  $h_1$  and  $h_2$ .

She calculated the difference in height  $\Delta h$  as  $21 \text{ mm} \pm 1 \text{ mm}$ .

Explain why it was appropriate to record the uncertainty in  $\Delta h$  as 1 mm.

(3)

(b) The student placed a small glass sphere at marker 1.

She released the sphere and used a stopwatch to measure the time  $t$  taken for the sphere to reach marker 2. She repeated this several times.

The student moved marker 2 to the lower end of the ramp and repeated the procedure.

Discuss how moving marker 2 to the lower end of the ramp could affect the percentage uncertainty in  $t$ .

(3)



(c) The time  $t$  is related to the acceleration due to gravity  $g$  by the formula

$$t^2 = \frac{14s^2}{5g\Delta h}$$

The student recorded the following data

$$s = 90.0 \text{ cm} \pm 0.1 \text{ cm}$$

$$\Delta h = 21 \text{ mm} \pm 1 \text{ mm}$$

$$t = 3.36 \text{ s} \pm 0.03 \text{ s}$$

(i) Determine the student's value of  $g$ .

(2)

$$g = \dots\dots\dots$$

(ii) Show that the percentage uncertainty in the student's value of  $g$  is about 7%.

(3)

(iii) Deduce whether the student's value of  $g$  is accurate.

(2)

(Total for Question 4 = 13 marks)

**TOTAL FOR PAPER = 50 MARKS**



### List of data, formulae and relationships

Acceleration of free fall	$g = 9.81 \text{ m s}^{-2}$	(close to Earth's surface)
Boltzmann constant	$k = 1.38 \times 10^{-23} \text{ J K}^{-1}$	
Coulomb's law constant	$k = 1/4\pi\epsilon_0$ $= 8.99 \times 10^9 \text{ N m}^2 \text{ C}^{-2}$	
Electron charge	$e = -1.60 \times 10^{-19} \text{ C}$	
Electron mass	$m_e = 9.11 \times 10^{-31} \text{ kg}$	
Electronvolt	$1 \text{ eV} = 1.60 \times 10^{-19} \text{ J}$	
Gravitational constant	$G = 6.67 \times 10^{-11} \text{ N m}^2 \text{ kg}^{-2}$	
Gravitational field strength	$g = 9.81 \text{ N kg}^{-1}$	(close to Earth's surface)
Permittivity of free space	$\epsilon_0 = 8.85 \times 10^{-12} \text{ F m}^{-1}$	
Planck constant	$h = 6.63 \times 10^{-34} \text{ J s}$	
Proton mass	$m_p = 1.67 \times 10^{-27} \text{ kg}$	
Speed of light in a vacuum	$c = 3.00 \times 10^8 \text{ m s}^{-1}$	
Stefan-Boltzmann constant	$\sigma = 5.67 \times 10^{-8} \text{ W m}^{-2} \text{ K}^{-4}$	
Unified atomic mass unit	$u = 1.66 \times 10^{-27} \text{ kg}$	

#### Unit 1

##### Mechanics

Kinematic equations of motion	$s = \frac{(u + v)t}{2}$
	$v = u + at$
	$s = ut + \frac{1}{2}at^2$
	$v^2 = u^2 + 2as$

##### Forces

$$\Sigma F = ma$$

$$g = \frac{F}{m}$$

$$W = mg$$

##### Momentum

$$p = mv$$

##### Moment of force

$$\text{moment} = Fx$$

##### Work and energy

$$\Delta W = F\Delta s$$

$$E_k = \frac{1}{2}mv^2$$

$$\Delta E_{\text{grav}} = mg\Delta h$$

##### Power

$$P = \frac{E}{t}$$

$$P = \frac{W}{t}$$

DO NOT WRITE IN THIS AREA

DO NOT WRITE IN THIS AREA

DO NOT WRITE IN THIS AREA



Efficiency

$$\text{efficiency} = \frac{\text{useful energy output}}{\text{total energy input}}$$

$$\text{efficiency} = \frac{\text{useful power output}}{\text{total power input}}$$

*Materials*

Density

$$\rho = \frac{m}{V}$$

Stokes' law

$$F = 6\pi\eta rv$$

Hooke's law

$$\Delta F = k\Delta x$$

Elastic strain energy

$$\Delta E_{\text{el}} = \frac{1}{2}F\Delta x$$

Young modulus

$$E = \frac{\sigma}{\varepsilon} \text{ where}$$

$$\text{Stress } \sigma = \frac{F}{A}$$

$$\text{Strain } \varepsilon = \frac{\Delta x}{x}$$

DO NOT WRITE IN THIS AREA

DO NOT WRITE IN THIS AREA

DO NOT WRITE IN THIS AREA



**Unit 2***Waves*

Wave speed  $v = f\lambda$

Speed of a transverse wave on a string  $v = \sqrt{\frac{T}{\mu}}$

Intensity of radiation  $I = \frac{P}{A}$

Refractive index  $n_1 \sin \theta_1 = n_2 \sin \theta_2$

$$n = \frac{c}{v}$$

Critical angle  $\sin C = \frac{1}{n}$

Diffraction grating  $n\lambda = d \sin \theta$

*Electricity*

Potential difference  $V = \frac{W}{Q}$

Resistance  $R = \frac{V}{I}$

Electrical power, energy  $P = VI$

$$P = I^2R$$

$$P = \frac{V^2}{R}$$

$$W = VI t$$

Resistivity  $R = \frac{\rho l}{A}$

Current  $I = \frac{\Delta Q}{\Delta t}$

$$I = nqvA$$

Resistors in series  $R = R_1 + R_2 + R_3$

Resistors in parallel  $\frac{1}{R} = \frac{1}{R_1} + \frac{1}{R_2} + \frac{1}{R_3}$

*Particle nature of light*

Photon model  $E = hf$

Einstein's photoelectric equation  $hf = \phi + \frac{1}{2}mv_{\max}^2$

de Broglie wavelength  $\lambda = \frac{h}{p}$

DO NOT WRITE IN THIS AREA

DO NOT WRITE IN THIS AREA

DO NOT WRITE IN THIS AREA



P 7 8 4 8 0 A 0 1 5 2 0

**Unit 4***Further mechanics*

Impulse

$$F\Delta t = \Delta p$$

Kinetic energy of a non-relativistic particle

$$E_k = \frac{p^2}{2m}$$

Motion in a circle

$$v = \omega r$$

$$T = \frac{2\pi}{\omega}$$

$$a = \frac{v^2}{r}$$

$$a = r\omega^2$$

Centripetal force

$$F = ma = \frac{mv^2}{r}$$

$$F = mr\omega^2$$

*Electric and magnetic fields*

Electric field

$$E = \frac{F}{Q}$$

Coulomb's law

$$F = \frac{Q_1 Q_2}{4\pi\epsilon_0 r^2}$$

$$E = \frac{Q}{4\pi\epsilon_0 r^2}$$

$$E = \frac{V}{d}$$

Electrical potential

$$V = \frac{Q}{4\pi\epsilon_0 r}$$

Capacitance

$$C = \frac{Q}{V}$$

Energy stored in capacitor

$$W = \frac{1}{2}QV$$

$$W = \frac{1}{2}CV^2$$

$$W = \frac{1}{2} \frac{Q^2}{C}$$

Capacitor discharge

$$Q = Q_0 e^{-t/RC}$$

DO NOT WRITE IN THIS AREA

DO NOT WRITE IN THIS AREA

DO NOT WRITE IN THIS AREA



Resistor-capacitor discharge

$$I = I_0 e^{-t/RC}$$

$$V = V_0 e^{-t/RC}$$

$$\ln Q = \ln Q_0 - \frac{t}{RC}$$

$$\ln I = \ln I_0 - \frac{t}{RC}$$

$$\ln V = \ln V_0 - \frac{t}{RC}$$

In a magnetic field

$$F = Bqv \sin \theta$$

$$F = BIl \sin \theta$$

Faraday's and Lenz's laws

$$\mathcal{E} = \frac{-d(N\phi)}{dt}$$

*Nuclear and particle physics*

In a magnetic field

$$r = \frac{p}{BQ}$$

Mass-energy

$$\Delta E = c^2 \Delta m$$

DO NOT WRITE IN THIS AREA

DO NOT WRITE IN THIS AREA

DO NOT WRITE IN THIS AREA



**Unit 5***Thermodynamics*

Heating  $\Delta E = mc\Delta\theta$

$$\Delta E = L\Delta m$$

Ideal gas equation  $pV = NkT$

Molecular kinetic theory  $\frac{1}{2}m\langle c^2 \rangle = \frac{3}{2}kT$

*Nuclear decay*

Mass-energy  $\Delta E = c^2\Delta m$

Radioactive decay  $A = \lambda N$

$$\frac{dN}{dt} = -\lambda N$$

$$\lambda = \frac{\ln 2}{t_{1/2}}$$

$$N = N_0 e^{-\lambda t}$$

$$A = A_0 e^{-\lambda t}$$

*Oscillations*

Simple harmonic motion  $F = -kx$

$$a = -\omega^2 x$$

$$x = A \cos \omega t$$

$$v = -A\omega \sin \omega t$$

$$a = -A\omega^2 \cos \omega t$$

$$T = \frac{1}{f} = \frac{2\pi}{\omega}$$

$$\omega = 2\pi f$$

Simple harmonic oscillator  $T = 2\pi\sqrt{\frac{m}{k}}$

$$T = 2\sqrt{\frac{l}{g}}$$

DO NOT WRITE IN THIS AREA

DO NOT WRITE IN THIS AREA

DO NOT WRITE IN THIS AREA



*Astrophysics and cosmology*

Gravitational field strength  $g = \frac{F}{m}$

Gravitational force  $F = \frac{Gm_1m_2}{r^2}$

Gravitational field  $g = \frac{Gm}{r^2}$

Gravitational potential  $V_{\text{grav}} = \frac{-Gm}{r}$

Stefan-Boltzmann law  $L = \sigma AT^4$

Wien's law  $\lambda_{\text{max}}T = 2.898 \times 10^{-3} \text{ m K}$

Intensity of radiation  $I = \frac{L}{4d^2}$

Redshift of electromagnetic radiation  $z = \frac{\Delta\lambda}{\lambda} \approx \frac{\Delta f}{f} \approx \frac{v}{c}$

Cosmological expansion  $v = H_0 d$

DO NOT WRITE IN THIS AREA

DO NOT WRITE IN THIS AREA

DO NOT WRITE IN THIS AREA



P 7 8 4 8 0 A 0 1 9 2 0

DO NOT WRITE IN THIS AREA

DO NOT WRITE IN THIS AREA

DO NOT WRITE IN THIS AREA

**BLANK PAGE**

